

## 50MPa Threaded-body single acting hydraulic cylinder

<b>TCS</b> Single Acting With Spring Return (version Without Female Thread)	
<b>TCZ</b> Single Acting With Spring Return (version With Female Thread)	
<b>TCH</b> Single Acting With Spring Return And Double Wiper (version Without Female Thread)	
<b>TCW</b> Single Acting With Spring Return And Double Wiper (version With Female Thread)	



- Threaded-body single acting clamp cylinder is small in size and can be applied to a clamping device, especially in small-size machinery or confined space.
- Light, beautiful and firm in design.

### Specification

Type	TCS TCZ	TCH TCW
Bore sizes of cylinder (mm)	φ 12, φ 16, φ 20, φ 25	
Power fluid	Filtered oil	
Material	Carbon steel	
The range of pressure (MPa )	10~50(100~500kgf/cm <sup>2</sup> )	
The range of temperature (°C)	-10 ~ +60	

### How to order

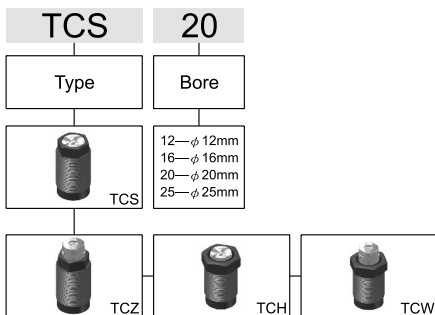

### Theoretic force

Item	Type	TCS(Z)12	TCS(Z)16	TCS(Z)20	TCS(Z)25
		TCH(W)12	TCH(W)16	TCH(W)20	TCH(W)25
Piston-φ D (mm)		12	16	20	25
Stroke (mm)		10	12	15	16
Clamping force at (KN)	10MPa	1.1	2	3.1	4.9
	50MPa	5.7	10.1	15.7	24.6
Min.pressure (MPa)		1	1	1	1
Spring return force Min. (N)		28	50	80	125
Oil volume per 10 mm stroke (cm <sup>3</sup> )		1.13	2.01	3.14	4.91
Seating torque (N · m)		40	50	60	80
Weight (kg)	TCS(Z)/TCH(W)	0.07 / 0.08	0.15 / 0.18	0.23 / 0.26	0.38 / 0.48

● **TCS TYPE** Bore  $\phi 12 \sim \phi 25$

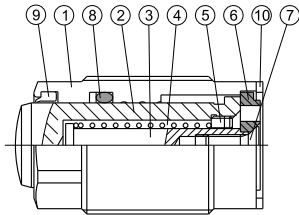

● **TCZ TYPE** Bore  $\phi 12 \sim \phi 25$

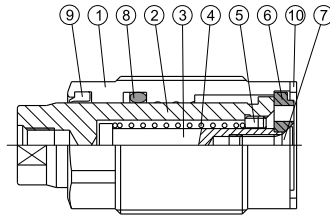

● **TCH TYPE** Bore  $\phi 12 \sim \phi 25$

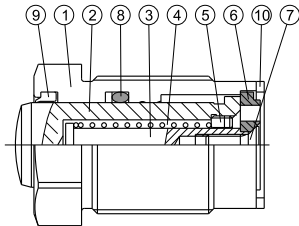

● **TCW TYPE** Bore  $\phi 12 \sim \phi 25$

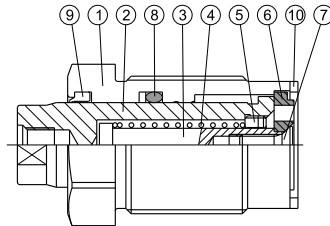

- TC
- TS
- RP
- HC
- HC\_M
- HCK
- TH
- DO
- DX
- DW
- DM
- DH
- DK

**Parts List**

No.	Part name	Quantity	No.	Part name	Quantity	No.	Part name	Quantity
1	Cylinder body	1	5	Fixed ring	1	9	Dust wiper	1
2	Piston rod	1	6	Support holder	1	10	Gasket	1
3	Fixed rod	1	7	Screws	1	11		
4	Spring	1	8	Rod packing	1	12		

**Points in usage:**

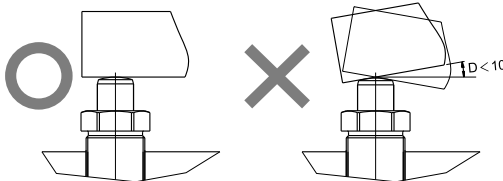

When installing, keep the contact angle between the rod and workpiece no larger than  $10^\circ$ .

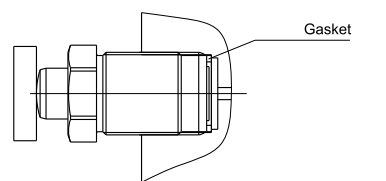

A leak-proof gasket is required to place under the bottom of cylinder barrel.

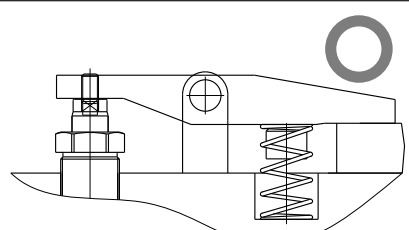

Don't just use for returning by spring of the hydraulic cylinder. Otherwise, the pulling application may not work.

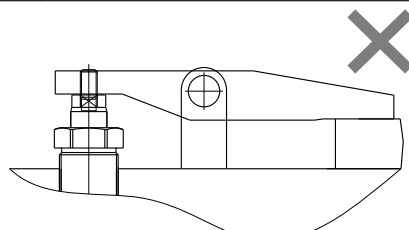

# TC Threaded-body Single Acting Hydraulic Cylinder **AEROTEK**

φ 12~ φ 25

## Dimensional features

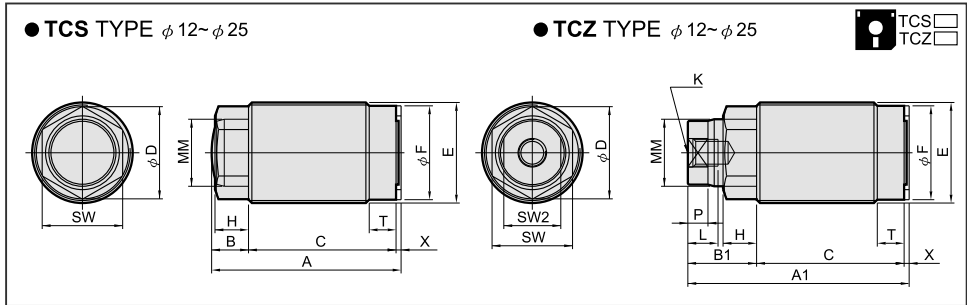

## Dimensional Table

Bore	A	A1	B	B1	C	D	E	F	H	K	L	φ MM	P	SW	SW2	T	X
φ 12	38.5	45.5	9	16	28	19	M22×1.5	20	6	M6×1.0	7	12	5.5	18	10	7	1.5
φ 16	47	53	12.5	18.5	33	24	M26×1.5	24	9	M6×1.0	7	16	5.5	22	13	8	1.5
φ 20	56.5	66	14	23.5	41	27.5	M30×1.5	28	10	M8×1.25	9	20	6	26	17	8	1.5
φ 25	60	69	15	24	43	36	M38×1.5	36	10	M8×1.25	9	25	7	33	19	11	2

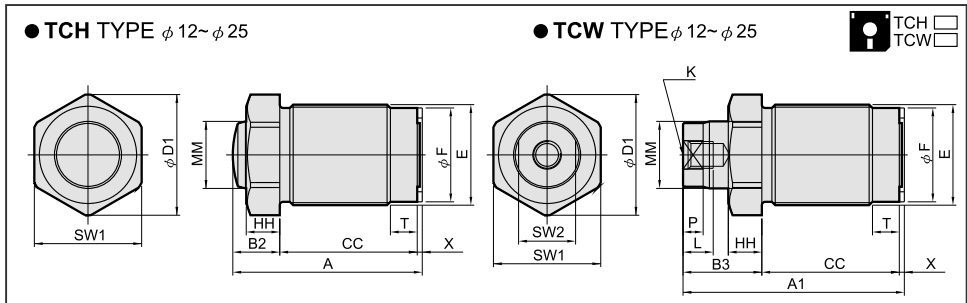

## Dimensional Table

Bore	A	A1	B2	B3	CC	D1	E	F	HH	K	L	φ MM	P	SW1	SW2	T	X
φ 12	38.5	45.5	12	19	25	27	M22×1.5	20	9	M6×1.0	7	12	5.5	24	10	7	1.5
φ 16	47	53	12.5	18.5	33	30.5	M26×1.5	24	9	M6×1.0	7	16	5.5	27	13	8	1.5
φ 20	56.5	66	14	23.5	41	36	M30×1.5	28	10	M8×1.25	9	20	6	32	17	8	1.5
φ 25	60	69	15	24	43	46.5	M38×1.5	36	10	M8×1.25	9	25	7	41	19	11	2

## Porting details

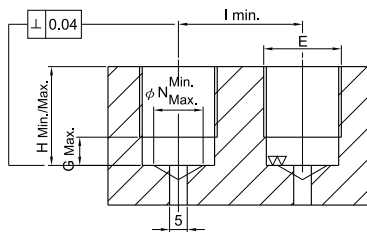

Bore	G Max.	TCS(Z) H Min./Max.	TCH(W) H Min./Max.	N Min./Max.	TCS(Z) I Min.	TCH(W) I Min.
φ 12	8	16.5/26.5	16.5/25	9/12	25	31
φ 16	9	20.5/31	20.5/33	12/16	30	34
φ 20	9	24.5/39.5	24.5/42	14/20	35	40
φ 25	11	28.5/42	28.5/44.5	18/25	43	52